



Assembly Manual For Angled Wall Mount – McLaren P1 (42172)

Mount Version – 2.1

Step 1:

- Insert the supplied 4 x Pins M3 x 10 into the lower frame as shown.

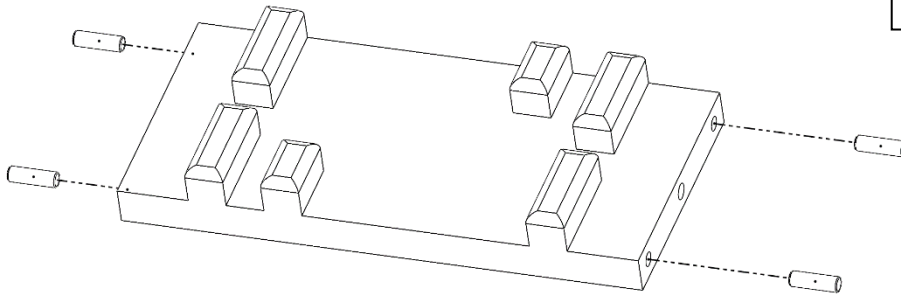

Step 2:

- Connect the rear frame to the right arm using 2 x M4x10 screws.
- Connect the lower frame to the right arm using 1x M4x20 screw.
- Don't over tighten!

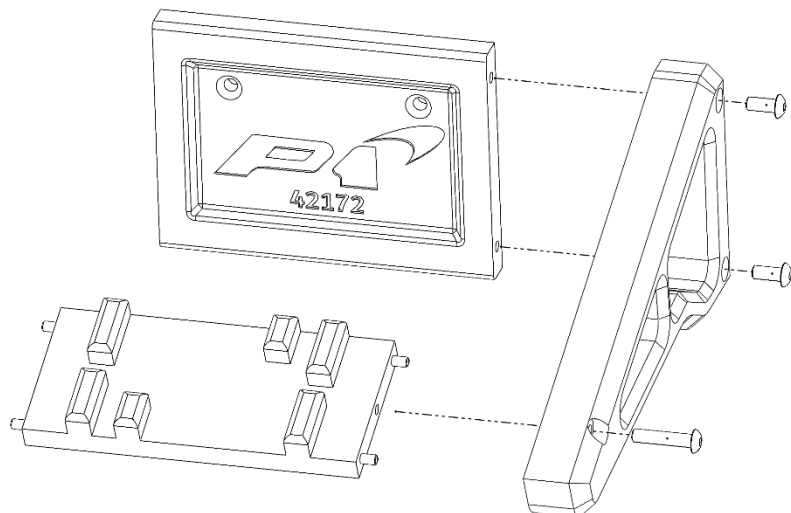

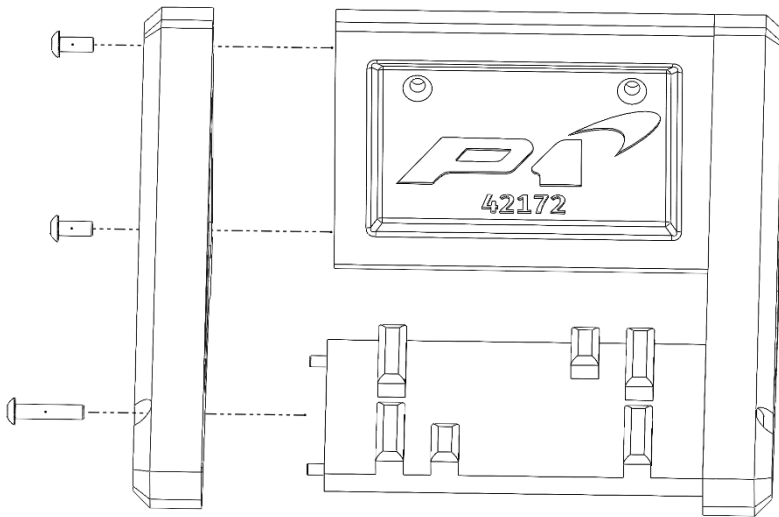

Step 3:

- Using the remaining screws. Connect the left arm to the mount assembly.
- Don't over tighten!

Step 4:

- For this step you will need the included 2x (4x25mm) screws and plugs.
- Mark out on your wall the holes for the back plate using it as a guide to where you want it to be.
- Drill out the holes and fit the plugs.
- Fasten the rear back plate to the wall ensuring its secure once complete.

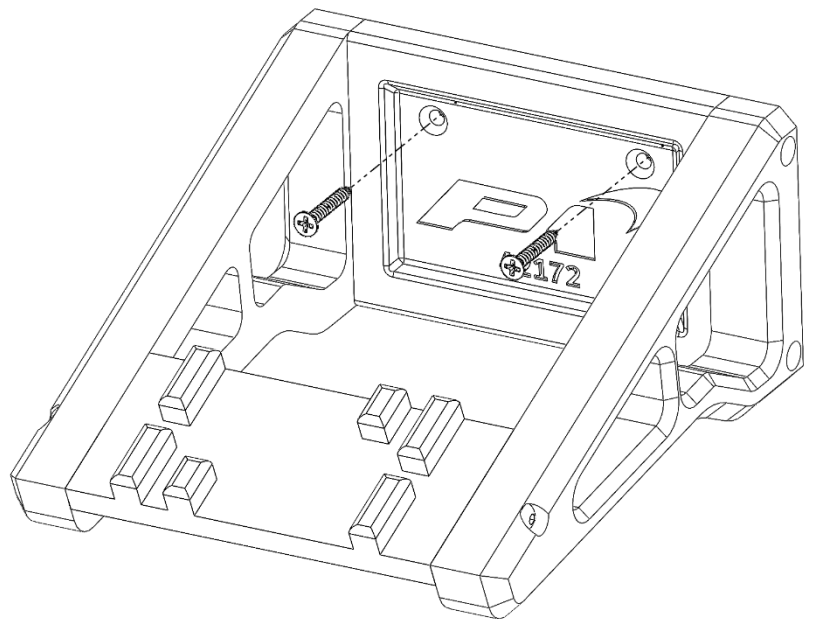

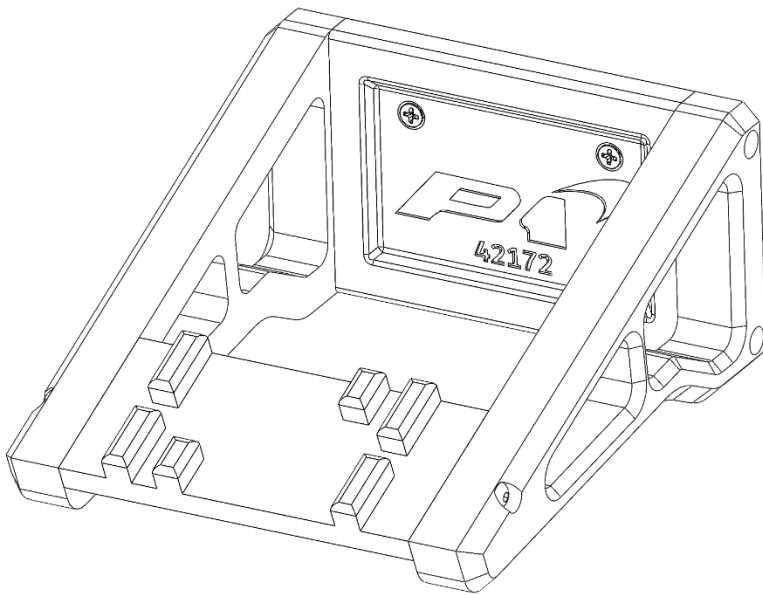

Completed Wall Mount:

- Check your wall mount is secure and matches the 3D model shown here.
- You are now ready to install the McLaren P1 to the mount locating this carefully onto the mounting points.

Please ensure the Lego set is structurally together before attempting to place on the wall mount.

For any technical support. Please get in touch at www.Odyssey3D.co.uk

Your feedback on my products is greatly appreciated and these mounts are constantly evolving based on this.

Thank you for your purchase and support.